



# HOTLOK®

Återförsäljare:

Tre Röda AB

Tillingehagby 7 - 745 94 ENKÖPING

Tel: 08-560 200 22

e-post: [info@treroda.nu](mailto:info@treroda.nu)

<http://www.treroda.nu>





# HOTLOK<sup>®</sup>

## HotLok<sup>®</sup> Blanking Panels

### Optimise Cooling Effectiveness, Eliminate Hotspots, Reduce Bypass Airflow – and save on Energy Costs!

#### With HotLok<sup>®</sup> Blanking Panels

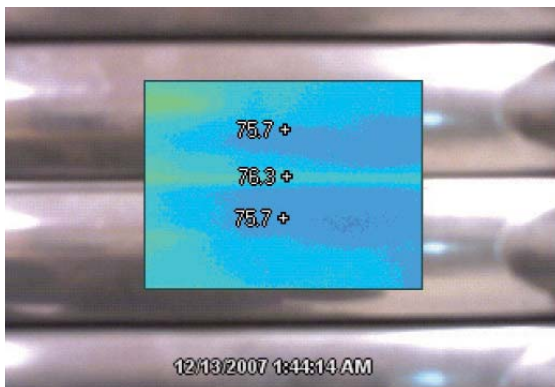

In a data centre with a conditioned airflow temperature of 72°F (22°C), a series of HotLok Blanking Panels are installed. The consistent temperatures shown on the face and gaps between the panels reveal the highly effective sealing technology.

#### With Conventional Blanking Panels



In a data centre with a conditioned airflow temperature of 72°F (22°C), and a series of non-HotLok Blanking Panels installed, the measured temperature of the heat radiating through the horizontal gaps is 91.5°F (33°C), which is much higher than the ASHRAE - recommended 77°F (25°C).

HotLok<sup>®</sup> Blanking Panels from Upsite Technologies provide a 99+ percent effective seal for both 1U and 2U openings in IT equipment cabinets and are a cost-effective, green solution for energy consumption savings and carbon footprint reduction in Data Centres. The lightweight plastic unit is ergonomically designed to facilitate fast, easy, safe, tool-free installation and removal and, depending on placement in the cabinet, HotLok<sup>®</sup> Blanking Panels help deliver more cool air to the upper one-third of the cabinet, which is typically the hottest section and most prone to hotspots and equipment reliability problems.

HotLok's energy-efficient cantilevered sealing vanes eliminate any gaps between adjoining HotLok<sup>®</sup> Blanking Panels or with installed equipment, providing a snug seal and no air leaks.

Awareness of best practices for cooling optimization has grown remarkably in the last couple of years and most IT managers fully appreciate the benefits of sealing gaps between rackmounted IT equipment in order to prevent hot exhaust air or hot-aisle air from migrating to the air-intake stream at the front of the cabinet.

What may be less well-known is that even the smallest gap between blanking panels can greatly reduce their effectiveness. Independent CFD Modeling tests, commissioned by Upsite Technologies, produced interesting results on a server cabinet with different levels of Blanking.\*

- **Cabinet with no blanking panels between servers:** 40% of the total airflow requirement was drawn in from hot exhaust air originating at the back of the server cabinet.
- **Cabinet with Blanking Panels with 1.6mm Horizontal Gap between panels:** The volume of hot exhaust air recirculation was reduced to 19% - an improvement of 53%.
- **Cabinet with HotLok<sup>®</sup> Blanking Panels Fitted:** The volume of hot exhaust air recirculation was reduced to **zero** - an improvement of 47% over the cabinet fitted with Blanking Panels with horizontal gaps, and a 100% improvement over the cabinet with no Blanking at all.

\*Figures from: White Paper "Two-Dimensional Computational Fluid Dynamics Analysis of Blanking Panel Solutions" and tests conducted by Kailash C. Karki, Ph.D., Innovative Research Inc.



Winner of the Best Product Award in the Infrastructure category

## HotLok Blanking Panel

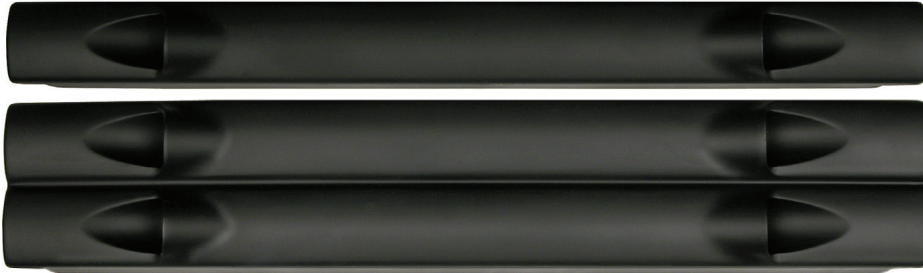

### Purpose

The HotLok® Blanking Panel is a snap-in blanking panel that provides a 99.97%+ effective seal in IT equipment cabinets. The state-of-the-art technology, designed for both 1U and 2U openings, controls airflow for optimized cooling effectiveness.

HotLok Blanking Panel is Upsite's latest green solution for energy savings and reducing the carbon footprint of data centers.

Both 1U- and 2U-configured versions achieve the following:

- Reduce hotspots and bypass airflow by preventing equipment exhaust air or hot-aisle air from migrating to the conditioned air-intake stream at the front of the cabinet
- Deliver lower temperature conditioned air to the upper one-third of the cabinet, typically the hottest area and most prone to equipment failure
- Control airflow to save energy by adjusting cooling unit setpoints

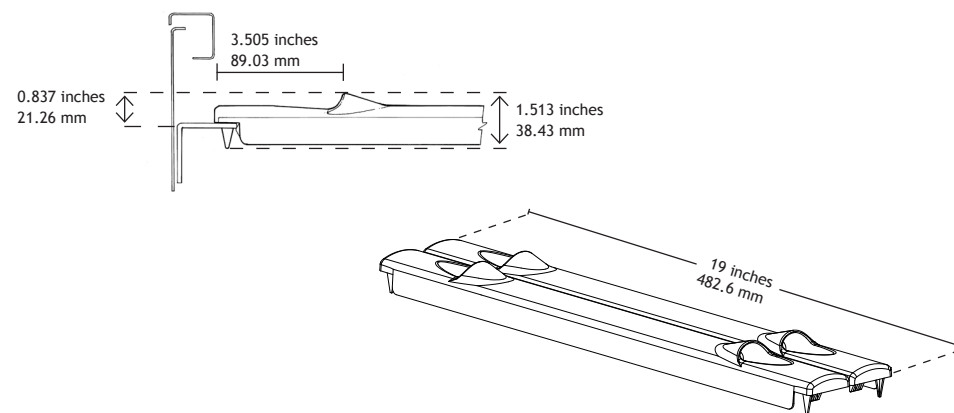

### Key Features

- Snap-spring design offers durable, 99.97%+ effective seal
- Tool-free, snap-in installation and easy-pull removal for any EIA-310-E standard openings using ergonomically designed finger grips
- Cantilevered sealing vanes eliminate the gap between adjoining Blanking Panels or with installed equipment
- 1U Panels stack 10 high and 2U Panels stack 20 high for easy storage and ready availability

### Applications

- Use 1U and 2U versions on cabinets with standard 19-inch rail widths (483 millimeter)
- Use with any standard EIA-310-E openings
- Use in a Hot and Cold Aisle layout for low or high heat density cabinets
- Use in existing cabinets for optimization and standardization

Upsite is an ENERGY STAR Service and Product Provider Partner, developing ways to optimize data centers and improve energy efficiency.



Base Product	Rack Rail Opening	Item Number	Quantity, Item Name
HotLok® 1U Blanking Panel	9.5mm Square	10015	Carton (10 Each) HotLok® 1U Blanking Panels - 9.5mm Square
	M5/10-32 Round	10031	Carton (10 Each) HotLok® 1U Blanking Panels - M5/10-32 Round
	M6/12-24 Round	10041	Carton (10 Each) HotLok® 1U Blanking Panels - M6/12-24 Round
HotLok® 2U Blanking Panel	9.5mm Square	10023	Carton (5 Each) HotLok® 2U Blanking Panels - 9.5mm Square
	M5/10-32 Round	10033	Carton (5 Each) HotLok® 2U Blanking Panels - M5/10-32 Round
	M6/12-24 Round	10043	Carton (5 Each) HotLok® 2U Blanking Panels - M6/12-24 Round

## Patent Pending Design

U.S. design patent number D577,360. Utility and international patents pending.

## Certifications and Conformance

**RoHS Compliant:** HotLok Blanking Panels are made of blended acrylonitrile butadiene styrene (ABS) that does not contain bromic compounds that have been found to be environmentally harmful.

**Recyclable:** The product is recyclable. In addition, all packaging is made with some post-consumer recycled content and is 100 percent recyclable.

## Warranty

HotLok Blanking Panels have a warranty for 12 months upon purchase date. The warranty can be extended from 12 to 28 months by registering the purchase online at [upsite.com/warranty](http://upsite.com/warranty).

## KoldLok Temperature Strip

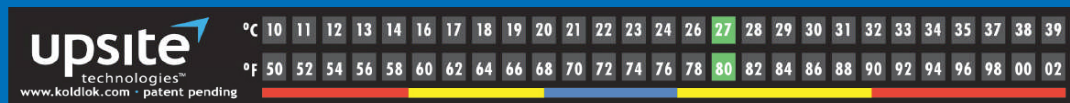

The KoldLok Temperature Strip is a liquid crystal thermometer with an acrylic self-adhesive backing that quickly and accurately measures the air-intake temperature of IT equipment. The Temperature Strip indicates if the air temperature is within acceptable limits based on standards established by the American Society of Heating, Refrigerating and Air-Conditioning Engineers (ASHRAE) and equipment manufacturers.

### Range & Limits

- The Strip measures in both Celsius (10°C to 39°C) and Fahrenheit (50°F to 102°F) temperature scales
- Blue area indicates optimal operating range as recommended by ASHRAE
- Yellow area indicates acceptable operating range based on equipment manufacturers' recommendations
- Red area outside acceptable operating range, indicates a definite hotspot above 32°C / 90°F or potential for condensation below 15°C or 59°F, either of which may result in equipment failure



## HotLok® Blanking Panels Reduce Intake Air Temperatures to Save Energy, Increase Capacity and Reduce Operating Expenses

As utility costs increase, budgets become tighter, and the need for higher densities grows, there is a rising demand to get as much capacity out of your existing data center space as possible—all while reducing operating expenses, and preserving availability and reliability.

Remediating airflow problems is often the most effective and least costly way to dramatically improve your data center's power usage effectiveness (PUE).

Installing HotLok Blanking Panels prevents circulation of hot exhaust air to reduce IT equipment intake-air temperatures. Efficiency improvements increase the cooling capacity of your data center infrastructure, so your business can reliably cool higher densities with existing infrastructure.

### Two separate studies demonstrate the HotLok Blanking Panel energy savings capabilities

#### Independent Two-Dimensional Computational Fluid Dynamics Modeling Study Results

Upsite commissioned an independent *Two-Dimensional Computational Fluid Dynamics Modeling Study* to compare hot exhaust air circulation in server cabinets with and without Hotlok blanking panels installed.

(See results on right)

#### Top

In a cabinet with unsealed open spaces, 40 percent of the IT equipment intake air is hot exhaust that has circulated from the back of the cabinet.

#### Bottom

The effective seal of HotLok Blanking Panels reduced the average intake-air temperatures by 7°F (3.9°C), saving operating and capital costs, and increasing current cooling efficiency. For complete study results visit [upsite.com](http://upsite.com).

#### Financial Impact Case Study Results

Upsite also conducted a *Financial Impact Study* to demonstrate how installing HotLok Blanking Panel allows data center managers to raise computer room temperatures and spend less of their budgets on cooling.

This resulted in a 29% reduction in annual operating costs, and full Return on Investment (ROI) was achieved in less than two months.

The test facility contained 400 cabinets in a computer room with 10,000 ft<sup>2</sup> of raised floor. Before installing HotLok, the facility required 61 CRAH units with a set point of 65°F to keep IT equipment intake air temperatures within acceptable ASHRAE levels.

After installing HotLok, the facility was able to turn off 18 CRAH units, and raise the CRAH temperature set points to 72°F, while still maintaining IT intake air temperatures within the acceptable ASHRAE recommended range. This resulted in a 29% reduction in annual operating costs, and full Return on Investment (ROI) was achieved in less than two months.

For complete study details, please see the back of this page.

Results from Two-Dimensional CFD Modeling Study

Before HotLok®

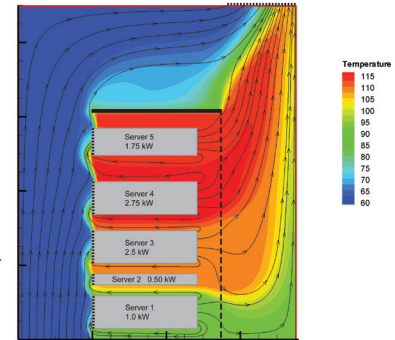

After HotLok®

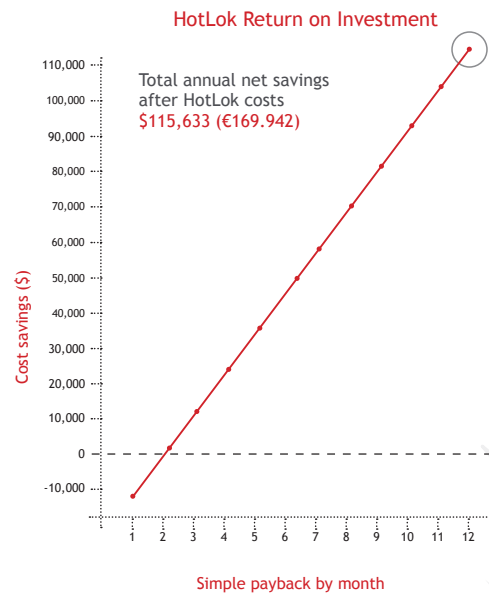
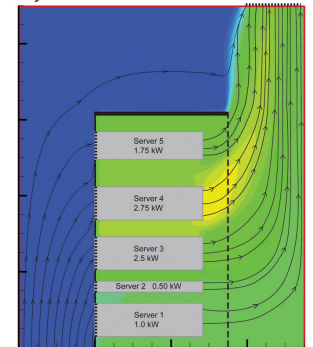

# HotLok Financial Impact Case Study

HotLok Blanking Panels Seal IT Equipment Cabinet Openings for Significant Energy Savings and Capacity Improvements

Profile of Chilled Water Liebert 600C Computer Room Air Handler (CRAH) Cooling Units in High-Heat Density Facility:

- 400 cabinets in a computer room with 10,000 ft<sup>2</sup> (approx 1,000 m<sup>2</sup>) of raised floor
- Each cabinet dissipates 8.5 kW of power, for a total critical load of 3.4 MW
- Heat density yield of 316 W/ft<sup>2</sup> (approx 3.400 W/m<sup>2</sup>)
- One third of cabinets (14U) contained no IT equipment and required blanking panels
- Of the one third requiring blanking panels, 40 percent (6U) are filled with 1U Panels and 60 percent (8U) are filled with 2U Panels
- The cost for Panels is the average selling price

**Before the HotLok Blanking Panel installation:** At 65°F (18.3°C) / 45% Rh, the 600C units have a 70 kW 100% sensible cooling capacity, therefore there is no latent cooling penalty in this calculation. For these return air conditions, a total of 61 CRAH units are required, 49 units at full cooling capacity and 12 for redundancy.

**After the HotLok Blanking Panel installation:** At 72°F (22.2°C) / 45% Rh, the 600C units have a 98 kW 100% sensible cooling capacity. For the 4.25 MW of total cooling capacity, a total of 43 CRAH units will be required, 35 units at full cooling capacity and 8 for redundancy.

PLEASE NOTE: There is no difference in the total cooling capacity as that takes place in the mechanical room and the chiller(s) will dissipate the same amount of heat no matter how many CRAH units are operating in the computer room. The chilled water flow rate will not be included for simplicity, although in actuality there may be additional savings associated with reduced chilled water flow rates.

Here's a summary of the operating cost savings available by installing HotLok Blanking Panels:

- (1) Increase return-air temperature set point by 7°F (3.9°C)—for this example, 65°F raised to 72°F (18.3°C raised to 22.2°C).
- (2) 18 units placed on inactive stand-by.

## Annual Operating Cost Savings

18 units with 10 hp fans X 0.757 kW/hp	136 kW
Annual energy consumption savings (8760 hrs / yr)	1,191,360 kWhrs
Annual cost savings at \$0.07 (€0.12) per kWhr	\$83,395 (€142,963)
Maintenance cost savings on 18 units (\$3,000 or €3,000 per unit)	\$54,000 (€54,000)
<b>Total annual operating cost savings</b>	<b>\$137,395 (€196,963)*</b>

\*This represents a 29 percent reduction in the annual operating and maintenance costs of the cooling units.

## Simple Payback Analysis

Cost and Savings	
# of cabinets	400
open U (1/3 of 42Us)	5,594
# of 1U Panels	2,238
# of 2U Panels	1,678
Total cost of Panels	\$21,762 (€27,021)
<b>Annual savings</b>	<b>\$137,395 (€196,963)</b>
<b>Monthly savings</b>	<b>\$11,450 (€16,414)</b>

Simple Payback												
Month	1	2*	3	4	5	6	7	8	9	10	11	12
US \$	-10,312	1,137	12,587	24,036	35,486	46,936	58,385	69,835	81,284	92,734	104,183	115,633
EU €	-10.607	5.806	22.220	38.633	55.047	71.461	87.874	104.288	120.701	137.115	153.529	169.942

### \*ROI Achieved

With the total annual cost savings at \$137,395 or \$11,450 per month (€196,963 or €16,413 per month), simple payback occurs in the second month of the HotLok Blanking Panel installation.

## Conclusion

The results of the Two-Dimensional Computational Fluid Dynamics Modeling Study and the Financial Impact Study underscore the importance of installing HotLok Blanking Panels, an industry-recognized best practice for airflow management. Sealing IT equipment server openings with HotLok Blanking Panels is among the simplest and most effective ways to reduce annual operating costs in the data center, improve PUE, and help you prepare for increasing server density, using your existing cooling infrastructure.

© Upsite Technologies, Inc. 2010. All rights reserved. UPSITE, UPSITE TECHNOLOGIES, THE ARROW DESIGN, KOLDLOK, HOTLOK, UPSITE SERVICES, and KOLDCHECK are trademarks of Upsite Technologies, Inc. in the US and other countries.

\*Other names and brands may be claimed as the property of others.

[upsite.com](http://upsite.com)